

CODE OF PRACTICE ON
Buildable Design

June 2002

CODE OF PRACTICE ON
Buildable Design

JUNE 2002

The Code of Practice on Buildable Design is published
by the Building and Construction Authority.

© Building and Construction Authority, June 2002

All rights reserved. No part of this publication may be
reproduced or transmitted in any form or by any means,
without permission in writing from the publisher.

ISBN 9971-88-745-2

Contents

CODE OF PRACTICE

1	Scope	2
2	Definitions	2
3	Statutory requirements	2
4	Buildability score requirements	3
5	Submission procedures for buildability	8
	score requirement	

ANNEX

A	Buildable Design Appraisal System	11
B	List of Application Forms	37

Introduction

The progressive tightening on supply of foreign workers and increasing demand for better quality make it necessary for the industry to adopt labour-efficient designs and use of more pre-assembled products. A key measure to achieve this is the introduction of government regulations under the Building Control Act to require building designs to have a minimum Buildability Score.

This Code sets out the requirements of minimum buildability and the submission procedures. It also sets out the method of determining the Buildability Score. Some amendments and revisions may be expected from time to time.

If you need clarification on any aspect of this Code of Practice, please contact the Building and Construction Authority, Singapore.

1 SCOPE

This Code of Practice sets out the minimum Buildability Scores for different categories of building, the submission procedures and the method for determining the Buildability Score of a building design.

2 DEFINITIONS

For the purpose of this Code, the following definitions shall apply:

Buildability	The extent to which the design of a building facilitates ease of construction.
Buildability Score	The score for buildability computed in accordance with Buildable Design Appraisal System as set out in the Code of Practice.
Minimum Buildability Score	The lowest Buildability Score allowed under a particular category of development stipulated in this Code.
Gross Floor Area	The gross floor area is calculated using the definition by the Urban Redevelopment Authority (URA).
Labour Saving Index	A value given to a particular building system which reflects the relative difference in site labour productivity associated with the various structural and wall systems.
Qualified Person (QP)	The Qualified Person shall be as defined in the Building Control Act, Chapter 29, Part I, Section 2.

3 STATUTORY REQUIREMENTS

3.1 Act and Regulations

The following Act and Regulations have relevance:

- a. The Building Control Act.
- b. The Building Control Regulations.
- c. The Building Control (Buildable Design) Regulations.

3.2 Responsibility

- 3.2.1** It is the responsibility of the owners, architects, engineers, contractors and others engaged in the design and construction of buildings to be conversant with the statutory requirements pertaining to Buildability Score. Designers should familiarise themselves with the Buildable Design Appraisal System (BDAS). This will enable them to consider a wider range of construction systems and products to meet the requirement for minimum buildability.
- 3.2.2** The owner shall engage the appropriate qualified persons to carry out buildable design. The QP for building works and the QP for structural works shall be responsible for ensuring that the buildability requirement is met. The two QPs shall jointly declare the Buildability Score achieved. The two QPs shall also jointly declare the As-built Buildability Score achieved.

4 BUILDABILITY SCORE REQUIREMENTS

4.1 Buildability Score

- 4.1.1** The Buildability Score of the building design shall be determined using this Code of Practice and the BDAS which is given in Annex A of this Code. BDAS may, from time to time, be amended, modified or replaced with a new edition. The latest edition in use shall be applicable.
- 4.1.2** Summary of the three areas of scoring
The Buildability Score of a project is made up of 3 parts:
- Part 1 – Structural System (maximum 50 points). Points are awarded for various types of structural systems used.
 - Part 2 – Wall System (maximum 30 points). Points are awarded for various types of wall systems used.
 - Part 3 – Other Buildable Design Features (maximum 20 points). Points are awarded for standardisation, modular dimensions, and use of precast/prefabricated components.

4.2 Types of Development

4.2.1 The minimum Buildability Score requirement shall apply to all new residential, commercial, industrial and institutional buildings and other projects with Gross Floor Area (GFA) equal to or greater than 5,000 m². In addition, mixed development with GFA equal to or greater than 5,000 m² will also be subjected to legislation. New extension or addition to existing buildings shall also be subjected to the requirements of minimum Buildability Score if the proposed building works involve increasing the GFA of the existing building by 5,000 m² or more. The various types of building development are categorised in Table A. Buildings listed under the First Schedule are exempted from the buildability requirement.

Table A Categories of Building

CATEGORIES	TYPES OF DEVELOPMENT
Residential (landed)	<ul style="list-style-type: none">• Terrace house• Semi-detached house• Bungalow• Clustered housing
Residential (non-landed)	<ul style="list-style-type: none">• Condominium• Flat• Service Apartment• Apartment• Dormitory• Hostel
Commercial	<ul style="list-style-type: none">• Bank• Departmental store• Shopping centre• Office building• Supermarket• Restaurant• Hotel• Conventional hall and facilities• Exhibition hall

Table A Categories of Building (*cont'd*)

CATEGORIES	TYPES OF DEVELOPMENT
Industrial	<ul style="list-style-type: none">• Factory• Warehouse• Godown• Brewery• Cold storage building• Packaging and processing plant• Printing plant• Sub-station
Institutional and others	<ul style="list-style-type: none">• Library• Hospital• Home for the aged• Childcare centre/Nursery• Research building• Educational facilities• Terminal building• Campus• Medical centre• Camps• Embassy• Museum• Crematorium and Columbarium• Club house• Cinema/theatre• Sports/recreational facilities• Public transport stations

The above list shall not be exhaustive. The QP is advised to seek clarification with BCA if his type of development is not stated in the above list.

4.2.2 For buildings not listed in the First Schedule, the QP may apply for exemption if the building has an uniqueness arising from special functional requirements. The exemption will be on a case-by-case basis. The application for exemption is to be submitted to the Commissioner of Building Control.

4.3 Minimum Buildability Score

4.3.1 The minimum Buildability Score for each category of development, namely residential projects, commercial projects, industrial projects and institutional and other projects shall be according to Table B. Different minimum Buildability Score requirements are given for $5,000 \text{ m}^2 \leq \text{GFA} < 25,000 \text{ m}^2$ and $\text{GFA} \geq 25,000 \text{ m}^2$.

Table B Minimum Buildability Score

CATEGORY OF BUILDING/ DEVELOPMENT	MINIMUM BUILDABILITY SCORE	
	$5,000 \text{ m}^2 \leq \text{GFA} < 25,000 \text{ m}^2$	$\text{GFA} \geq 25,000 \text{ m}^2$
Residential (landed)	54	57
Residential (non-landed)	60	63
Commercial	67	70
Industrial	69	72
Institutional and others	66	69

4.3.2 For building works whose application for planning permissions were made on or after 1st January 2001 but before 1st August 2002, the minimum buildability scores stipulated in the Code of Practice on Buildable Design December 2000 still apply.

4.3.3 Minimum Buildability Score for Mixed Development

The minimum Buildability Score for mixed development will be pro-rated according to the GFA of each type of development. For example, the minimum Buildability Score for a mixed development comprising 70% residential (non-landed) and 30% commercial is computed as follows:

Computation of Buildability Score for a Mixed Development with GFA between 5,000 m² and 25,000 m²

CATEGORY OF BUILDING	% OF BUILDING GFA	MINIMUM BUILDABILITY SCORE
		5,000 m ² ≤ GFA < 25,000 m ²
Residential (non-landed)	70% of GFA	70% of 60 = 42
Commercial	30% of GFA	30% of 67 = 20.1
The required minimum Buildability Score	100% of GFA	62 (rounded to nearest integer)

Computation of Buildability Score for a Mixed Development with GFA 25,000 m² and above

CATEGORY OF BUILDING	% OF BUILDING GFA	MINIMUM BUILDABILITY SCORE
		GFA ≥ 25,000 m ²
Residential (non-landed)	70% of GFA	70% of 63 = 44.1
Commercial	30% of GFA	30% of 70 = 21
The required minimum Buildability Score	100% of GFA	65 (rounded to nearest integer)

5 SUBMISSION PROCEDURES FOR BUILDABILITY SCORE REQUIREMENT

Buildability score will be one of the requirements for Building Plan (BP) approval. The BP will not be approved if the submitted buildability score is lower than the stipulated minimum. The buildability score is to be submitted by QPs at the following stages:

- BP stage
- ST (Structural plan) superstructural stage
- Temporary Occupation Permit (TOP)/Certificate of Statutory Completion (CSC) stage

5.1 Submission at BP Stage

The QPs shall indicate in Form BPD_BP03 (Application for Approval of Building Plans) whether Buildability Score calculations are applicable to the proposed building works. If applicable, the Buildability Score is to be submitted together with the BP submission using Form BPD_BS01. The Buildability Score is to be jointly declared by all QPs and the detailed computation of the Buildability Score attached. Forms BPD_BP03 and BPD_BS01 are given in Annex B.

5.2 Submission at ST Superstructural Stage

The current submission procedures allows the ST to be submitted separately from the BP. The structural buildability score is required to be submitted at the ST superstructural stage, if applicable. For each ST submission **before** BP submission, the QPs shall indicate in Form BEV/A1 (Application for Approval of Structural Plans) whether Buildability Score calculations are applicable to the proposed building works. If applicable, the Structural Buildability Score is to be submitted by the QP for Structural Works using Form BEV/A1_BS02. Forms BEV/A1 and BEV/A1_BS02 are given in Annex B.

5.3 Submission at TOP/CSC stage

5.3.1 Upon project completion, the QPs shall compute and declare the As-built Buildability Score and submit one set of the computation to BCA using Form BPD_BS03. This application is to be made within one month of obtaining TOP or before CSC, whichever is earlier. Form BPD_BS03 is given in Annex B.

5.3.2 BCA may conduct site checks during the construction stage.

First Schedule

BUILDING WORKS WHICH ARE NOT SUBJECTED TO THE MINIMUM BUILDABILITY REQUIREMENT

The types of development which are not subjected to the minimum buildability requirement are:

- (a) any culvert, bridge, underpass, tunnel, earth retaining or stabilising structure, slipway, dock, wharf, or jetty;
- (b) any theme park;
- (c) any place of worship;
- (d) any power station; or
- (e) any waste processing or treatment plant.

Annex A

BUILDABLE DESIGN APPRAISAL SYSTEM

Contents

1.0 INTRODUCTION	14
1.1 Objective	
1.2 Principles of Buildable Design	
1.3 Scope	
1.4 Buildability Score and Contractor's Productivity	
1.5 Rationale on Allocation of Points	
1.6 Rationale on Derivation of Labour Saving Indices	
1.7 Updates	
1.8 Development of Buildable Design Appraisal System, BDAS	
2.0 HOW TO USE THE BUILDABLE DESIGN	17
APPRAISAL SYSTEM, BDAS	
2.1 Components of the Appraisal System	
2.2 Computation of Buildability Score	
3.0 EXAMPLES ON COMPUTING	28
BUILDABILITY SCORE	
3.1 Single Block Building Project	
3.2 Multi-Block Building Project	

1.0 INTRODUCTION

The Buildable Design Appraisal System or BDAS was developed by the Building and Construction Authority as a means to measure of the potential impact of a building design on the usage of site labour. The appraisal system results in a 'Buildability Score' of the design. A design with a higher buildability score will result in more efficient labour usage in construction and therefore higher site labour productivity.

1.1 Objective

The objective of BDAS is to result in the wider use of buildable design. It is not the intention to adopt buildability at the expense of good architectural design. The need for more varieties and architectural features to satisfy clients' needs is recognised. There are, in fact, many examples of attractive designs that have high buildability scores.

Neither is the BDAS intended to solely promote prefabrication. Although, in general, prefabrication should give higher buildability scores, designs using simple cast-in-place construction can also yield reasonably high buildability scores.

Most importantly, buildable designs will lead to improvements in quality. This is due to the relative ease of construction and the need for fewer skilled tradesmen.

1.2 Principles of Buildable Design

The designer should first consider external factors such as soil condition, access and storage at the site, availability of resources, skills and technology, sequence of operations etc, to determine the most appropriate building system to be used. He can then apply the **3S** principles of *Standardisation*, *Simplicity* and *Single integrated elements* to achieve a buildable design.

Standardisation refers to the repetition of grids, sizes of components and connection details. A repeated grid layout, for example, will facilitate faster construction whether formwork or precast components are used. Similarly, columns or external claddings of repeated sizes will reduce the number of mould changes whether on-site or in the factory.

Simplicity means uncomplicated building construction systems and installation details. A flat plate system, for example, eases formwork construction as well as reinforcement work considerably. Use of precast components reduces many trade operations on site and should improve site productivity provided the standardisation principles are observed.

Single integrated elements are those that combine related components together into a single element that may be prefabricated in the factory and installed on site. Precast concrete external walls, curtain walls or prefabricated toilets are good examples of this.

1.3 Scope

BDAS therefore looks at the design and computes the extent to which the principles of standardisation, simplicity and single integrated elements are found. It covers the structural system and the major architectural components such as external and internal walls, doors and windows.

Points are awarded based on the types of structural and architectural system used. More points are awarded to the more buildable systems. The points are totalled to give the "Buildability Score" of the design.

1.4 Buildability Score and Contractor's Productivity

The particular Buildability Score for a design does not imply that every contractor will achieve the same level of site productivity when building that design. There are other factors that affect the contractor's output such as his management, quality of his sub-contractors and others. However, a high Buildability Score will imply that the same contractor should build that project with less site labour than one with a low Buildability Score.

1.5 Rationale on Allocation of Points

The computation of Buildability Score for a project involves the summation of Buildability Score attained for structural systems, wall systems and other buildable features. The maximum Buildability Score achievable for a project is 100 points.

The allocation of points to structural systems, wall systems and other buildable features is based on manpower consumption.

1.6 Rationale on Derivation of Labour Saving Indices

One of the more important factors in the appraisal system is the labour saving indices (LSIs). A labour saving index (LSI) is given to each building system. The building systems and indices will be updated regularly to reflect the changes in technology.

Projects were identified for each type of building system to undergo studies. Labour productivity, measured in square meter per manday, relating to each building system was analysed. Based on the relative difference in labour productivity, the labour saving index for each building system was derived. A high index indicates that the design is more buildable and fewer site workers are needed.

1.7 Updates

This Code of Practice on Buildable Design, June 2002, has included a number of updates.

1.7.1 Structural/Roof System

Several changes have been made to the structural system. The changes in Table 1 are listed below.

- (a) A new LSI is given for cast in-situ structures with transfer beams.

1.7.2 Wall System

Several changes have been made to the wall system. The changes in Table 2 are listed below.

- (a) A new LSI is given for precast concrete panel/wall with tiled/stone finish installed at the site.
- (b) The LSIs for PC formwork are revised.
- (c) New LSIs are included for cast in-situ RC wall with no finishes/pre-finished and cast in-situ RC wall with skim coat and paint finish.

1.7.3 Other Buildable Design Features

Several changes have been made to the other buildable design features. The changes in Table 3 are listed below.

- (a) Standard structural openings for doors in 2M or 3M modules are included.
- (b) The module requirement for pre-assembled/metal staircase is not required.
- (c) The percentage of coverage is changed to:
 - i) $\geq 65\%$ to $< 80\%$ instead of $> 65\%$ to $\leq 80\%$
 - ii) $\geq 80\%$ instead of $> 80\%$

1.8 Development of BDAS

The Buildable Design Appraisal System was developed with the assistance of a committee comprising leading local and foreign contractors who provided productivity data inputs from their projects. Inputs from various government agencies, consultants and product manufacturers were also incorporated.

The concern for buildability, or the need to integrate design with construction, has also been taken up in developed countries. In Japan, this integration is maximised as most projects proceed on a design-and-build basis. Major Japanese contractors such as Takenaka Corporation, Taisei Corporation and Kajima Corporation have developed their own in-house buildability appraisal systems. BCA's Buildable Design Appraisal System is modelled after Takenaka's system.

2.0 HOW TO USE THE BUILDABLE DESIGN APPRAISAL SYSTEM (BDAS)

2.1 Components of the Appraisal System

The BDAS provides a method to compute the Buildability Score of a design. It consists of three main parts:

- (a) the Structural System;
- (b) the Wall System; and
- (c) Other Buildable Design Features.

Buildability Score of the Structural System

A designer could use different structural systems for different parts of the building so as to achieve the best practical design. The Buildability Score for a particular structural system is the product of the percentage areas covered by the structural system and the corresponding labour saving indices available in Table 1 and Table 1A. These are summed up and multiplied by the weight factor to arrive at the Buildability Score of the total structural system. The maximum Buildability Score is 50 points.

Buildability Score of the Wall System

The Buildability Score for a particular wall system is computed by multiplying the percentage areas covered by the wall systems and the corresponding labour saving indices. These are summed up and multiplied by the weight factor to arrive at the Buildability Score of the total wall system. The maximum Buildability Score achievable in Table 2 is 30 points.

Buildability Score of Other Buildable Design Features

In this section, the buildability of the design is examined at the detailed level. Four basic design characteristics, namely standardisation of columns, beams, windows and doors, grids, prefabricated reinforcement and usage of precast components are considered. The use of these buildable design features will be awarded with points directly. The maximum Buildability Score that can be achieved in this section is 20 points.

2.2 Computation of Buildability Score

The Buildability Score formula is expressed as:

Buildability Score of Building	=	Buildability Score of Structural System (including Roof System) + Buildability Score of Wall System + Buildability Score of Other Buildable Design Features
BS	=	$50[\sum(A_s \times S_s)] + 30[\sum(A_w \times S_w)] + N$
where A_s	=	A_{sa} / A_{st}
A_w	=	A_{wa} / A_{wt}
A_s	=	Percentage of total floor area using a particular structural design
A_{st}	=	Total floor area which includes roof (projected area) and basement area
A_{sa}	=	Floor area using the particular structural design
A_w	=	Percentage of total external & internal wall areas using particular wall design
A_{wt}	=	Total wall area, excluding perimeter wall of the basement. All internal walls in the basement are to be considered.
A_{wa}	=	External & internal wall areas using particular wall design
S_s	=	Labour saving index for structural design (Table 1 & 1A)
S_w	=	Labour saving index for external & internal wall design (Table 2)
N	=	Buildability Score for other buildable design features (Table 3)

The Buildability Score of a project which consists of more than one building should be computed by multiplying the respective Buildability Score of the individual building with its percentage of the total floor area of that building in the project. That is,

$$BS_{\text{project}} = \text{Sum of } [BS_{\text{building}} \times (A_{st})_{\text{building}} / (A_{st})_{\text{project}}]$$

EXPLANATORY NOTES TO BUILDABILITY SCORE FORMULA

(a) Buildability Score of Structural System

The score for the structural system is based on the following:

Method for computation $50[\sum(A_s \times S_s)]$

A_s : The extent to which a particular structural system is used. This is expressed as a percentage of the total floor area of the building.

S_s : A labour saving index for the particular structural system. The labour saving indices for the various structural systems are given in Table 1 and 1A.

All structural systems used must be accounted for. If a combination of systems is used, then the contribution of each system is computed and summed up to arrive at the score. The maximum Buildability Score for the structural system is 50 points.

The total floor area is the total floor area constructed in the project, and includes roof (projected area) and basement area.

(b) Buildability Score of Wall System

The score for the wall system is based on:

Method for computation $30[\sum(A_w \times S_w)]$

A_w : The extent to which a particular external or internal wall system is used. This is expressed as a percentage of the total wall area of the building.

S_w : A labour saving index for the particular external or internal wall system. The labour saving indices for the various wall systems are given in Table 2.

All wall systems must be accounted for. If a combination of systems is used, then the contribution of each system is computed and summed up to arrive at the score. The maximum Buildability Score for wall system is 30 points.

The total wall area includes all external wall, window and door areas, and internal wall areas.

(c) Buildability Score of Other Buildable Design Features, N value

This section covers other design considerations that contribute to labour saving on site. Points are given for each labour saving method adopted and these are summed up to give the score, up to a maximum of 20 points. The points of various design considerations are given in Table 3.

TABLE 1 Structural Systems – S_s Value

SLAB/BEAM SYSTEM		CAST-IN-PLACE SLAB ON STEEL DECKING	PRECAST CONCRETE SLAB	CAST IN-SITU SLAB				
				FLAT PLATE	FLAT SLAB	1-WAY BANDED BEAM	2-WAY BEAM	SLAB/BEAM ⁽³⁾ ≤ 10
Steel beam	Steel beam and column sprayed fire proofed	0.95	0.90					
	Steel beam and column encased in concrete	0.85	0.80					
Precast concrete beam	With precast column/wall		1.00					
	With cast in-situ column/wall		0.90					
No internal beam	With precast column/wall			0.95/0.90 ⁽¹⁾				
	With cast in-situ column/wall			0.90/0.85 ⁽¹⁾	0.85/0.80 ⁽¹⁾			
Cast in-situ beam	With cast in-situ column/wall (without transfer beams)		0.75/0.70 ⁽¹⁾⁽²⁾			0.75/0.70 ⁽¹⁾	0.70/0.65 ⁽¹⁾	0.55/0.50 ⁽¹⁾
	With cast in-situ column/wall (with transfer beams) ⁽⁴⁾						0.40	

NOTE:

- (1) The higher index refers to cast in-situ post-tensioned or prestressed slabs/beams.
- (2) Both indices will apply where the value of slab area over number of beams is greater than 10. If the value of slab area over number of beams is less than or equal to 10, the index shall be 0.65 for post-tensioned/prestressed and 0.60 for non post-tensioned/non-prestressed.

(3)

- (4) Slab/beam refers to the value of slab area over number of beams.
- * The index of 0.40 is to be applied to the entire cast in-situ floor area with transfer beams, except area with ramp access.
- Indices for other systems not shown in this table shall be determined by BCA on a case by case basis. For such cases, the QPs are advised to seek BCA's comments before proceeding with the designs.

EXPLANATORY NOTES TO TABLE 1

- (a) The layout of Table 1 has been arranged in a matrix format. The column/beam systems are listed vertically and the slab/beam systems horizontally. The labour saving indices for the commonly used combinations of column/beam systems and slab/beam systems are given in the boxes. The combinations of column/beam systems and slab/beam systems that are not commonly used are shaded. In the event when a structural system used for a project is not stated in Table 1, the labour saving index shall be decided by BCA.
- (b) In the boxes with superscript (1), two labour saving indices are given. These structural systems have taken into consideration the effect of post-tensioning/prestressing. The higher index will be used when the structural system incorporates post-tensioned/prestressed beams or slabs.
- (c) In the boxes with superscript (2), the indices shown in the box applies when the value of the slab area over number of beams for the structural system is greater than 10. If the value of the slab area over number of beams is less than or equal to 10, the index shall be 0.65 for post-tensioned/prestressed and 0.60 for non-post-tensioned/non-prestressed.
- (d) For cast in-situ beam and slab construction, the slab/beam value is calculated by dividing the floor slab area over the number of beams supporting that floor area. A continuous beam across three columns is considered as two beams for the purpose of determining the value of slab area over number of beams. Similarly, a continuous beam across four columns is considered as three beams.
- (e) Flat plate refers to a slab design which does not have column heads or drop panels.

TABLE 1A Roof Systems - S_s Value

NO.	TYPES OF ROOF	S_s VALUE
a.	Integrated metal roof on steel truss	0.90
b.	Metal roof on steel truss	0.85
c.	Tiled roof on steel beam or precast concrete beam or timber beam	0.75
d.	Tiled roof with cast in-situ beam	0.55

EXPLANATORY NOTES TO TABLE 1A

Table 1A shows the labour saving indices, S_s , for various types of roof system. The indices for concrete roof depend on the type of structural system used and follow the respective index given in Table 1.

The integrated metal roof refers to prefabricated roofing system complete with insulation and can be installed as an entire roof section.

TABLE 2 Wall Systems – S_w Value

WALL	FINISHES	NO FINISHES/ PRE-FINISHED	PAINT FINISH	SKIM COAT & PAINT FINISH	PLASTER & PAINT FINISH	TILED/STONE FINISH	METAL/PLASTERBOARD CLADDING
Curtain wall/full height glass partition		1.00					
Precast concrete panel/wall ⁽¹⁾		0.95	0.85	0.80		0.95 ⁽⁴⁾	
Dry internal walls ⁽²⁾		1.00	0.90			0.65	
PC formwork ⁽³⁾		0.80	0.70	0.60		0.50	
Precision block wall				0.60		0.50	0.80
Cast in-situ RC wall		0.75	0.65	0.55	0.50	0.45	0.70
Brickwall	Brickwall				0.40	0.35	0.50
	Half fair-faced	0.40					
	Full fair-faced/ glass block	0.30					

NOTE:

- (1) Precast concrete panel/wall includes normal weight concrete panels, lightweight concrete panels, autoclaved aerated concrete panels.
- (2) Dry internal walls include sandwich panel wall system, stud and sheet partition wall systems, demountable wall systems.
- (3) PC formwork refer to precast formwork panel with concrete infill.
- (4) Tiled/stone is pre-installed in factory. For tiled/stone installed at site, LSI is 0.60.

*

Indices for other systems not shown in this table shall be determined by BCA on a case-by-case basis.

*

Index for windows/doors/prefabricated railings = 1

EXPLANATORY NOTES TO TABLE 2

- (a) The layout of Table 2 has been arranged in a matrix format. The wall types are listed vertically and the wall finishes horizontally. The labour saving indices for the commonly used combination of wall types and wall finishes are given in the boxes. The combination of wall types and wall finishes that are not commonly used, are shaded. In the event when a wall system used for a project is not stated in Table 2, the labour saving index shall be decided by BCA.
- (b) The index for windows, doors and prefabricated railings is 1.00.
- (c) The tiled/stone finish for precast concrete panel/wall is assumed to be installed in the factory. [Refer to box with superscript (4)]. For tiled/stone finish installed at the site, the index is 0.60.
- (d) Dry partitions refer to panels that do not require the use of water for erection. Examples are solid composite gypsum boards, cementitious panels or glass panels etc. Precision blocks refer to lightweight concrete blocks that have precised dimensions ($\pm 1\text{mm}$ dimensional tolerance) and can be laid on thin bed adhesive mortar.

TABLE 3 Other Buildable Design Features - N Value

BUILDABLE FEATURES		MODULE	UNIT OF COVERAGE	N VALUE	
				PERCENTAGE OF COVERAGE ⁽⁴⁾	
				≥ 65% TO < 80%	≥ 80%
1. Standardisation					
1.1	Columns (3 most common sizes)	0.5M ⁽²⁾	no.		2.00
1.2	Beams (3 most common sizes)	0.5M ⁽²⁾	no.		2.00
1.3	(a) Standard door leaf openings (width) (3 most common sizes) (see Table 3A)		no.	0.50	1.00
	OR				
	(b) Standard door leaf openings (width) and standard structural openings (3 most common sizes) (see Table 3A)		no.	1.00	2.00
1.3	OR				
	(c) Standard structural openings for doors (3 most common sizes) (for sizes not within the range stipulated in Table 3A)	2M or 3M	no.	0.50	1.00
1.4	Windows (3 most common sizes) ⁽¹⁾	1M/1M ⁽³⁾	no.	0.50	1.00
2. Grids					
2.1	Repetition of horizontal grids (between supports) (3 most common dimensions)	1M	no.	1.00	1.50
		3M	no.	1.50	2.00
2.2	Repetition of floor-to-floor height	0.5M	no.	1.00	2.00
2.3	Vertical repetition of structural floor layout		area	1.50	2.00
3. Prefabricated Reinforcement					
3.1	Floor		area	1.00	1.50
3.2	Wall		area	1.00	1.50
3.3	Beam cage		no.	1.50	2.00
3.4	Column cage		no.	1.50	2.00
4. Others					
4.1	(a) Prefabricated bathroom/toilet complete with piping/wiring; prefabricated wall panels and floor tray separately assembled	0.5M	no.	1.50	2.00
	OR				
4.1	(b) Prefabricated bathroom/toilet complete with piping/wiring; full prefabricated cell completed with finished wall and floor	0.5M	no.	2.00	3.00
	OR				
4.2	(a) Standard precast staircase (see Table 3B)		no.		2.00
	OR				
4.2	(b) Pre-assembled/metal staircase		no.		2.00
	OR				
4.3	Prefabricated vertical shafts (e.g. refuse chute ⁽⁵⁾)		no.		1.00
4.4	Multi-tier precast columns		no.		2.00
4.5	(a) Precast CD Shelters; minimum 2 panels precast	0.5M	no.	1.00	1.50
	OR				
4.5	(b) Precast CD Shelters; full precast cell	0.5M	no.	2.00	3.00
	OR				
4.6	Non-screed floor		area		1.00
4.7	Columns sit directly on top of piles		no.		0.50
4.8	Ground beams on top of pilecaps		no.		0.50
4.9	Diaphragm wall construction		area		1.50

NOTE:

(1) Sizes based on dimensions of frames.

(2) The module of 0.5M does not apply to steel structures.

(3) 1M for width and 1M for height (1M = 100 mm).

(4) The percentage of coverage is to be based on total floor

■ Not applicable area or on total number of components such as columns, beams, doors, windows etc.

(5) Points will be awarded for use of fully precast refuse chutes which have an external dimension of 850mm x 850mm or 1000mm x 1000mm.

EXPLANATORY NOTES TO TABLE 3

- (a) Table 3 shows the point given to each buildable design feature that contributes to labour saving on site. Points are summed up to form the Buildability Score for this section. The maximum score for this section is 20 points.
- (b) For item 1 – Standardisation, the criteria of minimum module must be met before points are given. M denotes 100mm. 0.5M implies that sizes must be in multiples of 50mm. 1M implies that sizes must be in multiples of 100mm.
- (c) For item 2 – Grids, the criteria of minimum module must be met before points are given. M denotes 100mm. Under repetition of horizontal grids, 3M implies that spacing between grids must be in multiples of 300mm. For repetition of floor to floor height, 0.5M implies that the floor to floor height must be in multiples of 50mm.
- (d) The unit of measurement for each type of design feature is in number, area or length. This is specified in the column entitled “Unit of Coverage.”
- (e) The percentage of coverage of each type of design feature is classified into 2 categories:
 - (i) $\geq 65\%$ to $< 80\%$
 - (ii) $\geq 80\%$

Please note that points will only be awarded to the use of prefabricated reinforcement/cages in cast in-situ floor, wall, beam and column. The use of prefabricated reinforcement/cages must be indicated on the plans.

The percentage of coverage is to be based on the total floor area or on the total number of components such as columns, beams, doors, windows etc.

Example for prefabricated reinforcement:

Area of precast floor = 3000 m²

Area of cast in-situ floor using prefabricated reinforcement (mesh) = 7000 m²

Total floor area = 10,000 m²

Percentage of coverage = area of cast in-situ area using mesh/total floor area
= 7000/10000
= 70%

Therefore points awarded = 1.0

- (f) BCA shall determine the points to be awarded or not to be awarded for other buildable features that are not stated in Table 3. For such cases, the QPs are advised to seek BCA's comments before proceeding with the designs.

TABLE 3A Standard Door Leaf Openings (Width) and Structural Openings⁽¹⁾

STRUCTURAL OPENING (HEIGHT) (MM) \ STRUCTURAL OPENING (WIDTH) (MM)	800	900	1000 ⁽³⁾	1200
2100	DLO(W): 740 ⁽²⁾	DLO(W): 840	DLO(W): 940	DLO(W): 1130
2200	DLO(W): 740	DLO(W): 840	DLO(W): 940	DLO(W): 1130
2400		DLO(W): 840	DLO(W): 940	DLO(W): 1130

■ Not applicable

EXPLANATORY NOTES TO TABLE 3A:

- (1) The standard structural openings (height) are listed vertically and the standard structural openings (width) listed horizontally. The standard door leaf openings (width) are given in the boxes. DLO(W) denotes standard Door Leaf Opening (Width).
- (2) To illustrate, the standard door leaf opening (width) in this box is 740mm. The standard structural opening size is 800mm x 2100mm. (See figure below)
- (3) The current fire code requires exit doors to have a minimum clear width of 850mm. (Designers are to refer to the fire code for details)

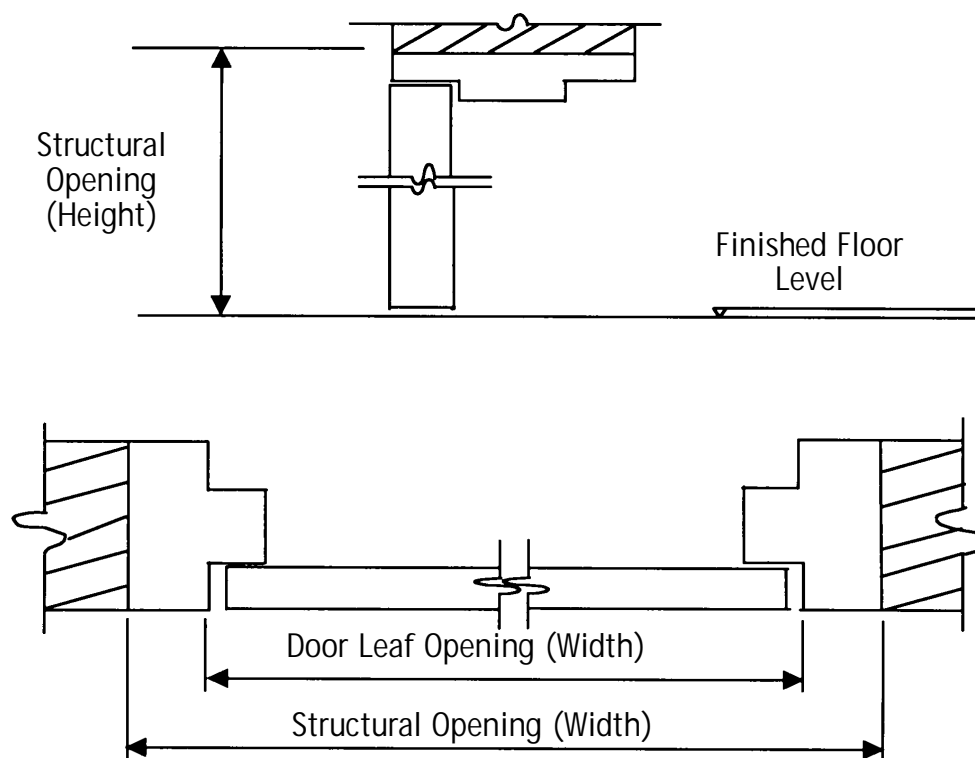

Definition of Door Leaf Opening and Structural Opening

TABLE 3B Standard Precast Staircase Size

RISER DIMENSION (MM)	FLOOR-TO-FLOOR HEIGHT (MM)				
	16 RISERS	18 RISERS	20 RISERS	22 RISERS	24 RISERS
150			3000	3300	3600
165			3300		
175	2800	3150	3500	3850	4200

NOTE:

- (1) Size of tread = 250mm, 275mm or 300mm (See figure below)
- (2) Higher floor heights in multiples of the above risers' dimensions will also be awarded with buildability points.
- (3) The number of risers may be manufactured in more than two flights.

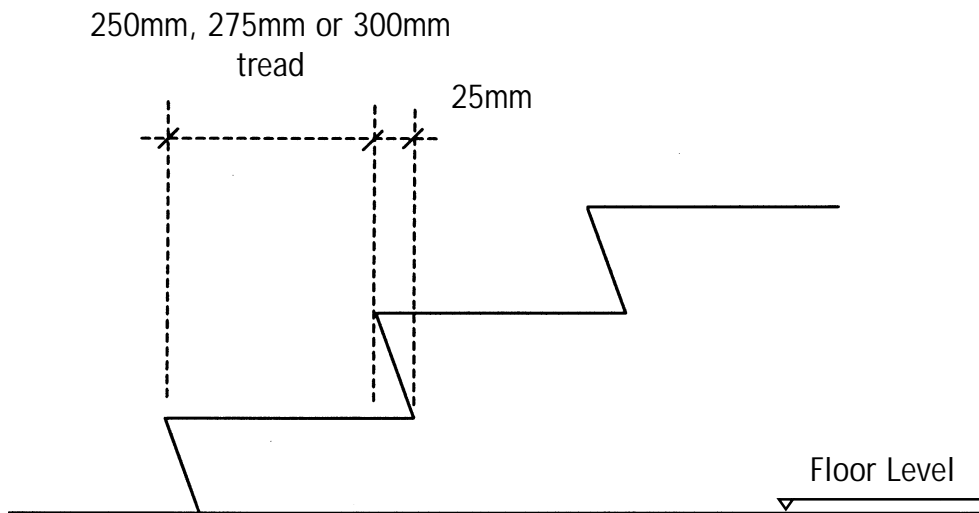
**Definition of Tread**

3.0 EXAMPLES ON COMPUTING BUILDABILITY SCORE

3.1 A SINGLE BLOCK BUILDING PROJECT

A. Project Information

- 1 block of 10-storey high residential apartment
- No basement
- Roof is of RC construction
- 4 apartment per storey
- For simplicity, assume typical floor layout for each floor, except 1st storey and roof
- Assume floor-to-floor height of 3.3m, except 1st storey, which is 4m high
- For area of building:

Total floor area of Apartments	= 10 x 667.40m ²	6,674.0m ²
Total floor area of Lift Lobby	= 10 x 86.6m ²	866.0m ²
Roof area (assume same as typical floor)		754.0m ²
A_{st} : Total floor area of building including roof area		<u>8,294.0m²</u>

B. Buildability Score Formula

$$BS = 50[\sum(A_s \times S_s)] + 30[\sum(A_w \times S_w)] + N$$

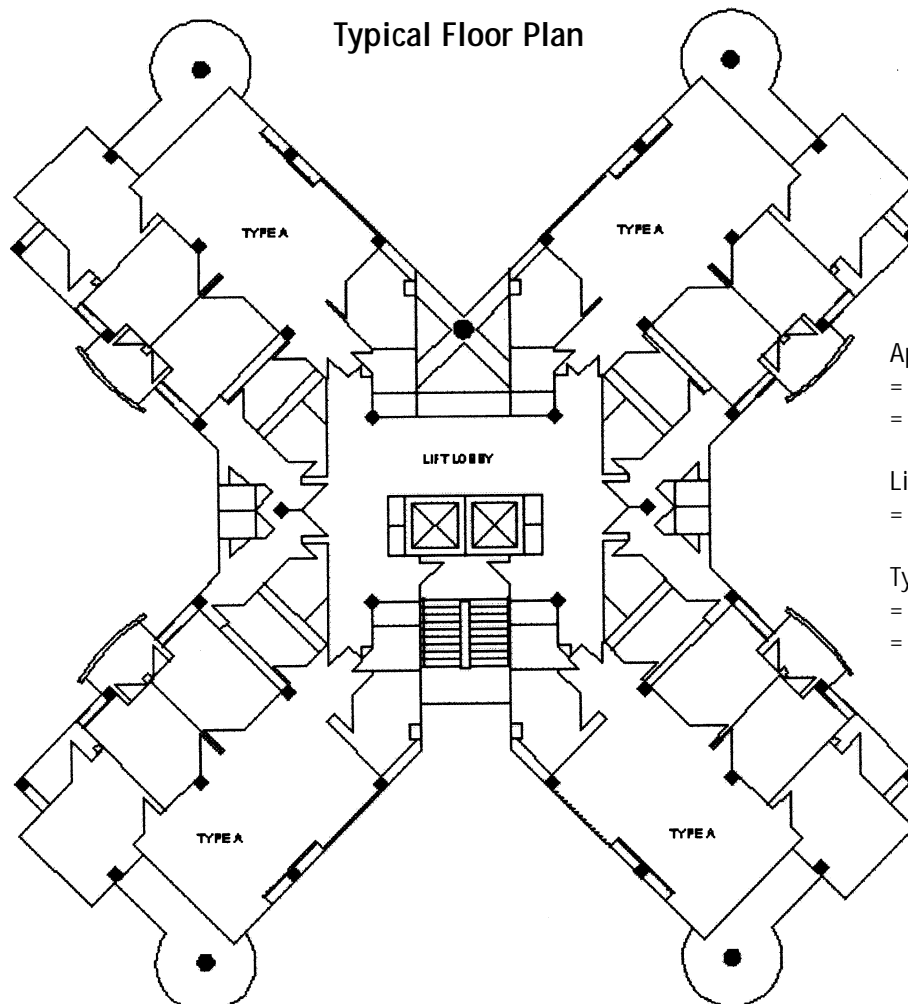

Apartment area per floor
 = 166.85 x 4
 = 667.4m²

Lift Lobby area per floor
 = 86.6m²

Typical floor area
 = 667.4 + 86.6
 = 754.0m²

C. Different Design Options

Consider four design options:

Option 1: Design based on conventional RC frame structure with external and internal brickwalls.

Option 2: Flat plate with cast in-situ columns design with external brickwalls and internal precision block partitions.

Option 3: Flat plate with cast in-situ columns design with precast external walls and internal precision block partitions.

Option 4: Design based on RC structure with cast in-situ columns, precast beams and precast slabs with external brickwalls and internal precision block partitions.

Typical Apartment Structural Floor Plan for Design Option 2 and Option 3

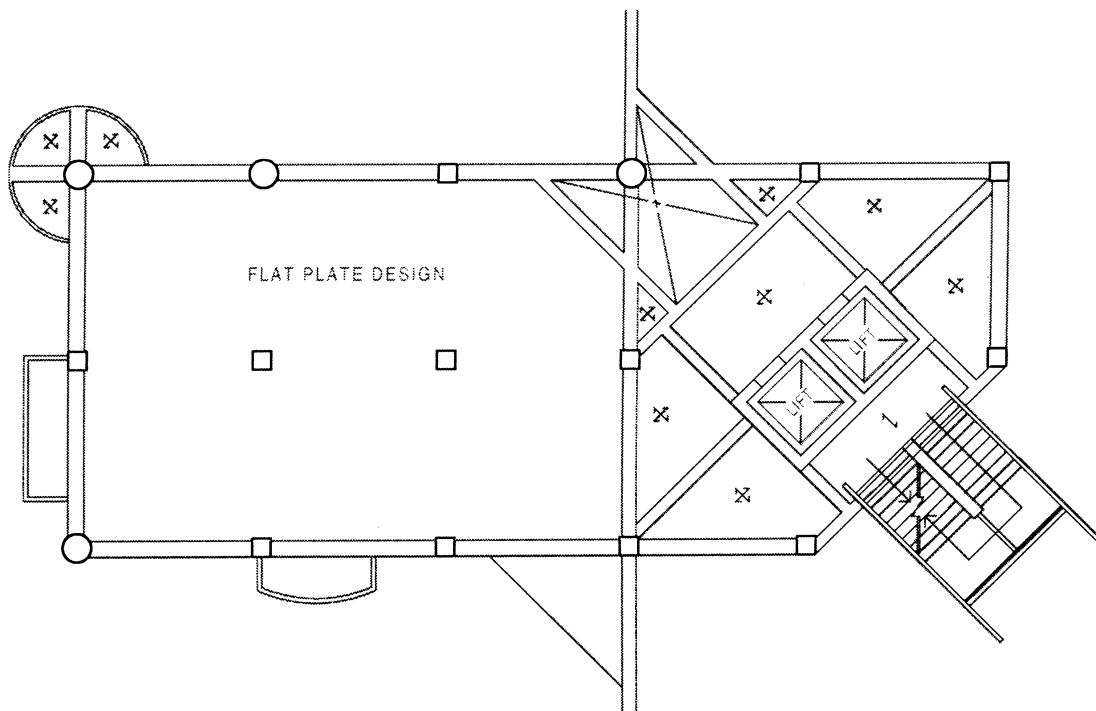

OPTION 1

Design based on conventional RC frame structure with external and internal brickwalls.

DESCRIPTION	AREA (M ²)	COVERAGE (%)	LABOUR SAVING INDEX	BUILDABILITY SCORE
Structural System				
(1) Cast in-situ slab with the value of slab area over number of beams greater than 10 Asa = 10 x 754.0 = 7,540m ² , Ast = 8,294m ²	7,540.0	91	S _s = 0.65	29.6
(2) RC flat roof	754.0	9	S _s = 0.65	2.9
Total (a)	8,294.0	100		32.5
Wall System				
(1) Windows & doors area	1,675.0	25	S _w = 1.00	7.5
(2) Brickwall with plaster & paint finish	5,025.0	75	S _w = 0.40	9.0
Total (b)	6,700.0	100		16.5
Other Buildable Features				
(1) Standardisation of columns 3S at 90%		90		N = 2.0
(2) Standardisation of beams 3S at 85%		85		N = 2.0
(3) Standardisation of door leaf openings (width) 3S at 95%		95		N = 1.0
(4) Standardisation of windows 3S at 95%		95		N = 1.0
(5) Repetition of horizontal grids (1M) (3 most common dimensions) 75%		75		N = 1.0
(6) Repetition of floor-to-floor height (0.5M) 90%		90		N = 2.0
(7) Vertical repetition of structural floor layout 82%		82		N = 2.0
(8) Ground beams on top of pilecaps 85%		85		N = 0.5
Total (c)				11.5
Buildability Score of Project (a) + (b) + (c)				61

OPTION 2

Flat plate design with cast in-situ columns with external brickwalls and internal precision block partitions.

DESCRIPTION	AREA (M ²)	COVERAGE (%)	LABOUR SAVING INDEX	BUILDABILITY SCORE
Structural System				
(1) Flat plate for apartment area + Roof Asa = 11 x 667.4 = 7,341.4m ² , Ast = 8,294m ²	7,341.4	89	S _s = 0.85	37.8
(2) RC beam/slab for lift lobby area + Roof Asa = 11 x 86.6 = 952.6m ² , Ast = 8,294m ² Value of slab area over number of beams less than 10 Note:- Roof design as in (1) and (2)	952.6	11	S _s = 0.50	2.8
Total (a)	8,294.0	100		40.6
Wall System				
(1) Windows & doors area	1,675.0	25	S _w = 1.00	7.5
(2) Brickwall with plaster & paint finish	3,015.0	45	S _w = 0.40	5.4
(3) Precision blocks with skim coat & paint finish	2,010.0	30	S _w = 0.60	5.4
Total (b)	6,700.0	100		18.3
Other Buildable Features				
(1) Standardisation of columns 3S at 90%		90		N = 2.0
(2) Standardisation of beams 3S at 85%		85		N = 2.0
(3) Standardisation of door leaf openings (width) 3S at 95%		95		N = 1.0
(4) Standardisation of windows 3S at 95%		95		N = 1.0
(5) Repetition of horizontal grids (1M) (3 most common dimensions) 75%		75		N = 1.0
(6) Repetition of floor-to-floor height (0.5M) 90%		90		N = 2.0
(7) Vertical repetition of structural floor layout 82%		82		N = 2.0
(8) Welded mesh for cast in-situ floor slabs 89% of total floor area		89		N = 1.5
(9) Ground beams on top of pilecaps 85%		85		N = 0.5
Total (c)				13.0
Buildability Score of Project (a) + (b) + (c)				72

OPTION 3

Flat plate design with cast in-situ columns with precast external walls and internal precision blocks partitions.

DESCRIPTION	AREA (M ²)	COVERAGE (%)	LABOUR SAVING INDEX	BUILDABILITY SCORE
Structural System				
(1) Flat plate for apartment area + Roof Asa = 11 x 667.4 = 7.341m ² , Ast = 8,294m ²	7,341.4	89	S _s = 0.85	37.8
(2) RC beam/slab for lift lobby area + Roof Asa = 11 x 86.6 = 952.6m ² , Ast = 8,294m ² Value of slab area over number of beams less than 10 Note:- Roof design as in (1) and (2)	952.6	11	S _s = 0.50	2.8
Total (a)	8,294.0	100		40.6
Wall System				
(1) Windows & doors area	1,675.0	25	S _w = 1.00	7.5
(2) Precast concrete panel with paint finish	2,010.0	30	S _w = 0.85	7.7
(3) Brickwall with plaster & paint finish	1,005.0	15	S _w = 0.40	1.8
(4) Precision blocks with skim coat & paint finish	2,010.0	30	S _w = 0.60	5.4
Total (b)	6,700.0	100		22.4
Other Buildable Features				
(1) Standardisation of columns 3S at 90%		90		N = 2.0
(2) Standardisation of beams 3S at 85%		85		N = 2.0
(3) Standardisation of door leaf openings (width) 3S at 95%		95		N = 1.0
(4) Standardisation of windows 3S at 95%		95		N = 1.0
(5) Repetition of horizontal grids (1M) (3 most common dimensions) 75%		75		N = 1.0
(6) Repetition of floor-to-floor height (0.5M) 90%		90		N = 2.0
(7) Vertical repetition of structural floor layout 82%		82		N = 2.0
(8) Welded mesh for cast in-situ floor slabs 89% of total floor area		89		N = 1.5
(9) Ground beams on top of pilecaps 85%		85		N = 0.5
Total (c)				13.0
Buildability Score of Project (a) + (b) + (c)				76

OPTION 4

Design based on RC structure with cast in-situ columns, precast concrete beams and precast concrete slabs with external brickwalls and internal precision block partitions.

DESCRIPTION	AREA (M ²)	COVERAGE (%)	LABOUR SAVING INDEX	BUILDABILITY SCORE
Structural System				
(1) PC concrete beam and PC concrete slab	7,540.0	91	$S_s = 0.90$	41.0
(2) RC cast in-situ flat roof Value of slab area over number of beams greater than 10	754.0	9	$S_s = 0.65$	2.9
Total (a)	8,294.0	100		43.9
Wall System				
(1) Windows & doors area	1,675.0	25	$S_w = 1.00$	7.5
(2) Brickwall with plaster & paint finish	3,015.0	45	$S_w = 0.40$	5.4
(3) Precision blocks with skim coat & paint finish	2,010.0	30	$S_w = 0.60$	5.4
Total (b)	6,700.0	100		18.3
Other Buildable Features				
(1) Standardisation of columns 3S at 90%		90		N = 2.0
(2) Standardisation of beams 3S at 85%		85		N = 2.0
(3) Standardisation of door leaf openings (width) 3S at 100%		100		N = 1.0
(4) Standardisation of windows 3S at 100%		100		N = 1.0
(5) Repetition of horizontal grids (1M) (3 most common dimensions) 75%		75		N = 1.0
(6) Repetition of floor-to-floor height (0.5M) 90%		90		N = 2.0
(7) Vertical repetition of structural floor layout 82%		82		N = 2.0
(8) Standard precast staircase 90%		90		N = 2.0
(9) Ground beams on top of pilecaps 85%		85		N = 0.5
Total (c)				13.5
Buildability Score of Project (a) + (b) + (c)				76

3.2 A MULTI-BLOCK BUILDING PROJECT

A. Project Information

This project consists of 8 blocks of buildings:-

- 3 blocks of 3-storey high workshop (Block A, B & C)
- 2 blocks of 2-storey high workshop (Block D & E)
- 1 block of 2-storey high multi-purpose hall (Block F)
- 1 block of 2-storey high classroom (Block G)
- 1 block of 2-storey high classroom cum administration (Block H)

A_{st} , total floor area including roof (projected area), of each building is as below:

• Block A, B & C	$A_{st} = 2,700m^2$ per building
• Block D	$A_{st} = 3,000m^2$
• Block E	$A_{st} = 2,400m^2$
• Block F	$A_{st} = 2,600m^2$
• Block G	$A_{st} = 1,000m^2$
• Block H	$A_{st} = 3,600m^2$
Overall project	$A_{st} = 20,700m^2$

Layout plan for a multi-block building project

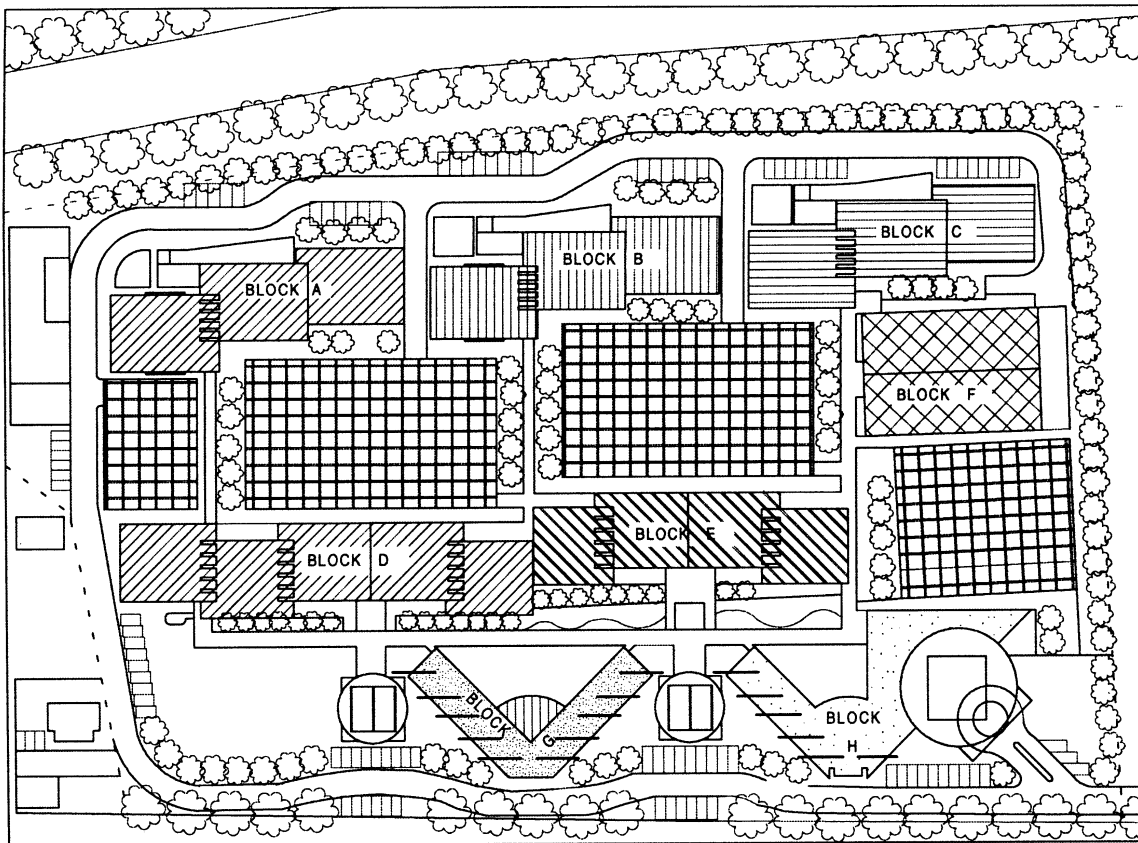

The design of the buildings is as follow:

- Structural System:
 - (1) Block A, B, C, D, E & F - cast in-situ flat plate with metal roof on steel truss
 - (2) Block G & H - cast in-situ beam & slab with the value of slab area over number of beams is smaller than 10
- Wall System:
 - (1) All the blocks - 50% precast panel with paint finishing, 30% windows & 20% brickwalls with plaster & paint finishing
- Other Buildable Features:
 - (1) Repetition of horizontal grids 85% (3M) (3 most common dimensions) - All blocks except block H
 - (2) Standardised column sizes - 3S at 90%
- All blocks except block H which achieves a standardisation of 3S at 85%
 - (3) Standardised beam sizes - 3S at 90%
- All blocks except block H which achieves a standardisation of 3S at 85%
 - (4) Standardised preassembled staircase (min 85%)
- Block A, B, C, D & E
 - (5) Welded mesh for cast in-situ floor slabs (min 85%)- All blocks
 - (6) Standardised door leaf openings (width) - 3S at 85%
- All blocks
 - (7) Standardised window sizes - 3S at 85%
- All blocks
 - (8) Ground beams sit on top of pilecaps (min 85%)
- All blocks

B. Buildability Score

The Buildability Score (BS) for the respective blocks is as follows:

- Block A : BS = 79.0 $(A_{st})_{bldg} / (A_{st})_{proj} = 0.13$
- Block B : BS = 79.0 $(A_{st})_{bldg} / (A_{st})_{proj} = 0.13$
- Block C : BS = 79.0 $(A_{st})_{bldg} / (A_{st})_{proj} = 0.13$
- Block D : BS = 79.0 $(A_{st})_{bldg} / (A_{st})_{proj} = 0.14$
- Block E : BS = 79.0 $(A_{st})_{bldg} / (A_{st})_{proj} = 0.12$
- Block F : BS = 77.0 $(A_{st})_{bldg} / (A_{st})_{proj} = 0.13$
- Block G : BS = 59.2 $(A_{st})_{bldg} / (A_{st})_{proj} = 0.05$
- Block H : BS = 57.2 $(A_{st})_{bldg} / (A_{st})_{proj} = 0.17$

The Buildability Score of the project is computed as below:

$$\begin{aligned}
 BS_{proj} &= \text{Sum of } [BS_{bldg} \times (A_{st})_{bldg} / (A_{st})_{proj}] \\
 &= \underline{74}
 \end{aligned}$$

Annex B

LIST OF APPLICATION FORMS

LIST OF APPLICATION FORMS

ITEM	DESCRIPTION	FORMS
1	Application for approval of building plans	BPD_BP03
2	Submission of buildability score calculations	BPD_BS01
3	Application for approval of structural plans	BEV/A1
4	Submission of structural buildability score calculations	BEV/A1_BS02
5	Submission of as-built buildability score calculations	BPD_BS03

APPLICATION FOR APPROVAL OF BUILDING PLANS
Section 6 of the Building Control Act (Cap.29 – 1999 Ed.)

Commissioner of Building Control
 Building & Construction Authority
 5 Maxwell Road #02-00
 Tower Block, MND Complex
 Singapore 069110
 Website: <http://www.bca.gov.sg/>

INSTRUCTIONS

- 1 One copy of this form is to be submitted. If an item is not applicable it is to be indicated as "N/A".
- 2 * Delete accordingly.
- 3 Please tick (✓) in the appropriate boxes.
- 4 This form is to be filled in BLACK INK only.

SECTION I (To be completed by Applicant)

1 I hereby apply for approval of building plans for:-

Project Reference Number: _____

Description of building works: _____

*Lot/Plot: _____ *TS/MK: _____

Address: _____

Name of development: _____

2 In accordance with section 6(3) of the Act, I have appointed _____ as the qualified person in respect of the building works herein described.

Address of Applicant

Name & Signature of Applicant (in the case of a company include the designation of the authorised signatory)

Tel No.:

NRIC No./Passport No.:

Date:

SECTION II (To be completed by Qualified Person)

1 I confirm that I have been appointed under section 6(3) of the Act as the qualified person in respect of the building works herein described. I certify that the building works shown in the plans submitted with this application are in accordance with the Act and the building regulations, subject to such waiver/modification granted under section 14 of the Act.

2 I hereby declare that the particulars required for this application and as stated in these forms are correct.

3 Waiver application forms *are attached/not applicable.

4 i) I certify that the requirements of the relevant Technical Authorities/Departments have been complied with and the respective clearances as listed below are attached.

Technical Department/Authorities	Technical Department/Authorities
(a)	(f)
(b)	(g)
(c)	(h)
(d)	(i)
(e)	(j)

ii) Notwithstanding that the outstanding clearances from _____ (state technical departments) will be obtained within the next 2 weeks, their requirements have already been complied with. These clearances when obtained will be submitted to the Commissioner of Building Control for record.

5 I confirm that -

- i) planning permission for the building works is not applicable;
- ii) the building works have been submitted to the Chief Planner, Urban Redevelopment Authority under the lodgement scheme; or
- iii) planning permission for the building works is applicable and has been granted by the Competent Authority. The written permission *together with the approved site plan () in DC _____ is attached/is granted under electronic submission.

I hereby declare that (if item (ii) or (iii) is ticked):

- (a) the building plans do not deviate from the plan submitted to URA as lodgement under Submission No: _____;
- (b) the building plans do not deviate from *approved plan () in DC _____/Electronic submission approval no: _____;
- (c) the building plans contain minor deviations from *approved plan () in DC _____/Electronic submission approval no: _____. These minor deviations are covered in the list of items exempted from Planning Permission as issued by the Competent Authority.
- (d) the building plans contain minor deviations from *approved plan () in DC _____/Electronic submission approval no: _____. These minor deviations, although not specifically exempted from planning permission, do not give rise to additional GFA beyond the approved GFA nor do they attract additional development charge or differential premium (whichever is applicable). The minor deviations have also not departed from the planning controls on building setback, overall building height (amsl), floor-to-floor height, site coverage, platform level, use quantum and height of basement protrusion.

6 I confirm that household/storey shelter work is -

- i) not applicable and the reason(s) being (tick as appropriate):
- (a) there is no residential dwelling in the building works.
- (b) application for planning permission for the building works was submitted to URA before 1 May 98 and URA's planning permission has not lapsed or become invalid.
- (c) building works involve additions and alterations where there is no household/storey shelter or where addition & alteration works do not affect the existing household/storey shelter.
- (d) reconstruction not involving a total demolition of existing residential building.
- ii) applicable and I will obtain Notice of Acceptance of shelter plans from Special Functions Division of BCA.

7 The building works have *not commenced/commenced on _____ (date) *with/without a permit to carry out building works.

8 OTTV plans and calculations are -

- i) not applicable;
- ii) applicable and a set of these calculations are attached.

9 Buildable design calculations are -

- i) not applicable, the reason being:
- gross floor area less than 5000m². [Regulation 3(2) of the Building Control (Buildable Design) Regulations (Cap 29)]
- waiver obtained.
- exempted under Regulation 3(3) of the Building Control (Buildable Design) Regulations.
- buildability score submitted in the previous BP submission. There is no change to the buildability score declared previously.
- application for planning permission for the building works was made before 1 January 2001.

ii) applicable and a set of these calculations (Form BPD_BS01) is attached. The buildability score is _____ . The 1st application for planning permission for the building works was made on:

1st Jan 2001 - 31st July 2002

on or after 1st Aug 2002

10 The information related to buildability score is given below (tick as appropriate):

i) Gross floor area of proposed building:-

$\geq 5000\text{m}^2$ but less than 25000m^2 $\geq 25000\text{m}^2$

ii) Category of building (for mixed developments, more than 1 box may be ticked)

Residential (landed) Residential (non-landed) Commercial

Industrial Institutional and others

11 Other documents necessary for the consideration of approval of the building plans are attached herewith.

Address of Qualified Person		Name & Signature of Qualified Person	
Tel No.:	Fax No.:	Reg No. (*Arch/PE):	Date:

PLAN FEE COMPUTATION FOR BUILDING PLANS/STRUCTURAL PLANS
[Regulations 108 to 111 of the Building Control Regulations (Cap.29, Rg 5)]

PART I (Computation of Plan Fees for Building Plans/Structural Plans)

S/N	Type of Building Works	Area/Storey/Sub	Rate	Computed Fees	Official Use
1	New Building/Building Works	Statistical Gross Floor Area (m ²)	\$200/100 m ²	\$	
2	New structures	Plan Area (m ²)	\$200/100 m ²	\$	
3	Addition/Alteration Works or Amended Plans [any increase in area to be computed under item (1) above]	No. of Storeys	\$100/storey	\$	
4	Minor Works (including works not listed above and amendment to these works)	\$100 per submission		\$	
Total Plan Fees Payable				\$	
				\$	Penalty Plan Fees for unauthorised works (_____ times total)
<p>I confirm that the plan fees payable are in accordance with PART VII of the Building Control Regulations (Cap 29, Rg 5), for the building works shown in the *building plan/structural plan of Project Ref No.: _____.</p>					<p>Checked By:</p> <p>_____</p> <p>(Signature & Name of Officer)</p>
<p>_____</p> <p>Name & Signature of Qualified Person</p>			<p>_____</p> <p>Date</p>		<p>_____</p> <p>Date</p>

EXPLANATORY NOTES TO FORM BPD_BP03 & FORM BPD_BP03 APPENDIX 1

(A) APPLICATION FORM

- (1) Every application shall be accompanied by -
 - (a) 1 set of building plans with the project reference number printed at the top right-hand corner on every sheet of the plans and one copy of the site plan drawn in accordance with the provisions of the Regulations (scale between 1:200 to 1:1000);
 - (b) Where applicable, an application(s) for the Modification/Waiver of Building Regulations - Form BPD_BP05; and
 - (c) Where applicable, the Written Permission (Notice of Grant of Approval) including only the site plan approved by the Competent Authority under Planning Act (Development Control Division, URA).
 - (d) Clearances from the relevant technical authorities/departments.
 - (e) Where applicable, OTTV submission form (Form BPD_BP04), plans and calculations.
- (2) The plans for building works shall be prepared in accordance with the relevant provisions in Part II of the Building Control Regulations.
- (3) The Qualified Person appointed under Section 6(3) of the Act shall be according to the type of projects or building works as determined under the First Schedule to the Building Control Regulations.
- (4) The Qualified Person who prepares the building plans shall certify on every sheet of the drawings as follows:-

“I, _____ hereby certify, subject to any waiver/modification granted under Section 14 of the Act, that the preparation of these building plans and the building works shown on these plans are strictly in accordance with the provisions of the Building Control Act (Cap 29) and the Regulations made thereunder”.

Signature of Qualified Person

Date

- (5) In the case of any building plans for repairs, alterations or additions to an existing building issued with a Certificate of Statutory Completion or a Temporary Occupation Permit -

Where the Qualified Person who prepares the building plans reasonably suspects that the building works may affect the structural stability or integrity of the building, every sheet of the drawings shall bear a certificate from a Professional Engineer (Civil) or (Structural) as follows:-

“I have inspected the building and investigated its overall structure and that, in my opinion, the building is capable of resisting the forces and moments which may be increased or altered by reason of the repairs, alterations or additions shown on these plans”.

Stamp & Signature of Professional Engineer

Date

OR

“I have inspected the building and investigated its overall structure and that, in my opinion, the building with its structural elements strengthened in accordance with the structural plans *submitted on _____/to be submitted for approval before submission of the Joint Application For Permit To Commence *Piling/ Structural/Building Works, will be capable of resisting the forces and moments which may be increased or altered by reason of the repairs, alterations or additions shown on these plans”.

Stamp & Signature of Professional Engineer

Date

- (6) Building developments with Provisional Permissions (“PPs”) issued before 15 September 2000, are required to comply with the Singapore Broadcasting Authority (“SBA”)’s directions and recommendations concerning the installation and provision of cable-ready Master Antenna Television (MATV) system.

Building developments with Provisional Permissions issued on and after 15 September 2000, are required to comply with the Info-communications Development Authority of Singapore (“IDA”)’s directions and recommendations in accordance with the Code of Practice for Info-Communications Facilities in Buildings (“COPIF”). For buildings, which are six storeys and above, developers are also required to comply with the “tap off-pipes” directions issued by SBA.

A letter from the Qualified Person indicating receipt and retention of Singapore Cable Vision’s Certificate of Cable Readiness must be submitted before the issuance of the Certificate of Statutory Completion.

(B) FEE COMPUTATION FORMAT (APPENDIX 1)

- (1) One copy of this form is to be submitted.
- (2) Payment of fees shall preferably be made by cheque in favour of the “BUILDING & CONSTRUCTION AUTHORITY, SINGAPORE”.
- (3) The statistical gross floor area (SGFA) means the aggregate of the “gross floor areas” and “other areas”.
- (4) A certified true copy of forms submitted to URA Development Control Division on the Statistical Gross Floor Area (PR 16G) is to be attached for the purpose of confirming building plan fees. Please ensure that PR 16G also reflects other areas such as carpark, swimming pool and others.
- (5) If alterations to an existing building or amendments to an approved plan under S/N (3) involve an increase in the floor area, the fee for the new area shall be computed according to S/N (1).

**SUBMISSION OF BUILDABILITY SCORE CALCULATIONS
Regulation 5 of the Building Control (Buildable Design) Regulations (Cap.29)**

Commissioner of Building Control
Building & Construction Authority
5 Maxwell Road #02-00
Tower Block, MND Complex
Singapore 069110

INSTRUCTIONS

- 1 Please refer to the Explanatory Notes attached before completing these forms.
- 2 Use a separate set of BPD_BS01_Appendix 1 for each block of the building in the project.
- 3 *Delete accordingly.
- 4 Please use BLACK INK to complete the form.
- 5 One copy of this form together with Form BPD_BS01_Appendix 1 is to be submitted with the application for approval of building plans.

SECTION I (To be completed by all Qualified Persons)

1 We confirm that we are the qualified persons appointed in respect of the building works herein described under Section 6(3) of the Building Control Act (Cap 29).

Project Reference No.: _____

Description of building works: _____

2 We hereby declare that the buildability score submitted herewith complies with the minimum buildability requirement under the Building Control (Buildable Design) Regulations and the computation of the buildability score is as stated in Form BPD_BS01_Appendix 1. We further declare that the particulars required for this submission and as stated in these forms are correct. The total buildability score for the proposed building works is _____.

Name & Address of Professional Firm

Name & Signature of Qualified Person for architectural works

Date:

Tel No.:

Name & Address of Professional Firm

Name & Signature of Qualified Person for structural works

Date:

Tel No.:

CALCULATIONS OF OVERALL BUILDABILITY SCORE
Regulation 5 of the Building Control (Buildable Design) Regulations (Cap.29)

PART I : PROJECT DETAILS

Project Reference No.: _____
 Block No./Name: _____ Total no. of blocks: _____
 Please indicate other typical blocks (if any): _____

Category of Building (for mixed development, more than 1 box may be ticked):

Residential (landed) Residential (non-landed) Commercial
 Industrial Institutional & others

For mixed development, please indicate the GFA for each category:

Residential (landed) _____ m²
 Residential (non-landed) _____ m²
 Commercial _____ m²
 Industrial _____ m²
 Institutional & others _____ m²

PART II : COMPUTATION OF BUILDABILITY SCORE

STRUCTURAL SYSTEM	AREA (M ²) (a)	% AREA (b)	LABOUR SAVING INDEX (c)	BUILDABILITY SCORE (b) x (c) x 50
1 STEEL BEAM				
1.1 Steel beam with column in sprayed fire proofed with:				
1.1.1 cast-in-place slab on steel decking			0.95	
1.1.2 precast concrete slab			0.90	
1.2 Steel beam with column encased in concrete with:				
1.2.1 cast-in-place slab on steel decking			0.85	
1.2.2 precast concrete slab			0.80	
2 PRECAST CONCRETE BEAM				
2.1 with precast column/wall with precast concrete slab			1.00	
2.2 with cast in-situ column/wall with precast concrete slab			0.90	
3 NO INTERNAL BEAM				
3.1 with precast column/wall				
3.1.1a with flat plate (post-tensioned/prestressed)			0.95	
3.1.1b with flat plate (without post-tensioned/prestressed)			0.90	
3.2 with cast in-situ column/wall				
3.2.1a with flat plate (post-tensioned/prestressed)			0.90	
3.2.1b with flat plate (without post-tensioned/prestressed)			0.85	
3.2.2a with flat slab (post-tensioned/prestressed)			0.85	
3.2.2b with flat slab (without post-tensioned/prestressed)			0.80	

STRUCTURAL SYSTEM	AREA (M ²) (a)	% AREA (b)	LABOUR SAVING INDEX (c)	BUILDABILITY SCORE (b) x (c) x 50
4 CAST IN-SITU BEAM AND COLUMN/WALL				
4.1 precast concrete slab (without transfer beams) (slab/beam>10) with:				
4.1.1a cast in-situ beams (post-tensioned/ prestressed)			0.75	
4.1.1b cast in-situ beams (without post-tensioned/ prestressed)			0.70	
4.2 precast concrete slab (without transfer beams) (slab/beam≤10) with:				
4.2.1a cast in-situ beams (post-tensioned/ prestressed)			0.65	
4.2.1b cast in-situ beams (without post-tensioned/ prestressed)			0.60	
4.3 cast in-situ slab (without transfer beams) (slab/beam >10) with:				
4.3.1a 1-way banded beam with slabs/beams (post-tensioned/prestressed)			0.75	
4.3.1b 1-way banded beam with slabs/beams (without post-tensioned/prestressed)			0.70	
4.3.2a 2-way beam with slabs/beams (post-tensioned/prestressed)			0.70	
4.3.2b 2-way beam with slabs/beams (without post-tensioned/prestressed)			0.65	
4.4 cast in-situ slab (without transfer beams)(slab/beam ≤ 10) with:				
4.4.1a slabs/beams (post-tensioned/prestressed)			0.55	
4.4.1b slabs/beams (without post-tensioned/prestressed)			0.50	
4.5 cast in-situ slabs (with transfer beams) - applicable to projects submitted for planning approval on or after 1 st Aug 2002 only			0.40	
5 ROOF SYSTEM				
5.1 Integrated metal roof on steel truss			0.90	
5.2 Metal roof on steel truss			0.85	
5.3 Tiled roof on steel beam or PC concrete beam or timber beam			0.75	
5.4 Tiled roof with cast in-situ beam			0.55	
5.5 Concrete roof (constructed area shall be included in the slab design above)				
6 OTHER STRUCTURAL SYSTEMS NOT LISTED IN BDAS				
Total floor area including roof area				
			Sub-total for structural system (A) (maximum 50 points)	

WALL SYSTEM		AREA (M ²) (a)	% AREA (b)	LABOUR SAVING INDEX (c)	BUILDABILITY SCORE (b) x (c) x 30
1	WINDOWS/DOORS/PREFABRICATED RAILINGS			1.00	
2	CURTAIN WALL/FULL HEIGHT GLASS PARTITION				
2.1	No finishes/pre-finished			1.00	
3	PRECAST CONCRETE PANEL/ WALL (includes normal weight concrete panels, lightweight concrete panels, autoclaved aerated concrete panels)				
3.1	No finishes/pre-finished			0.95	
3.2	With paint finish			0.85	
3.3	With skim coat & paint finish			0.80	
3.4	With tiled/stone finish (tile/stone pre-installed in factory)			0.95	
3.5	With tiled/stone finish (tile/stone installed at site)			0.60	
4	DRY INTERNAL WALLS (include sandwich panel wall system, stud and sheet partition wall systems, demountable wall systems)				
4.1	No finishes/pre-finished			1.00	
4.2	With paint finish			0.90	
4.3	With tiled/stone finish			0.65	
5	PC FORMWORK				
5.1	With no finishes/pre-finished			0.80	
5.2	With paint finish			0.70	
5.3	With skim coat and paint finish			0.60	
5.4	With tiled/stone finish			0.50	
6	PRECISION BLOCKWALL				
6.1	With skim coat and paint finish			0.60	
6.2	With tiled/stone finish			0.50	
6.3	With metal/plasterboard cladding			0.80	
7	CAST IN-SITU RC WALL				
7.1	With no finishes/pre-finished			0.75	
7.2	With paint finish			0.65	
7.3	With skim coat and paint finish			0.55	
7.4	With plaster & paint finish			0.50	
7.5	With tiled/stone finish			0.45	
7.6	With metal/plasterboard cladding			0.70	
8	BRICKWALL				
8.1	Brickwall				
8.1a	with plaster & paint finish			0.40	
8.1b	with tiled/stone finish			0.35	
8.1c	with metal/plasterboard cladding			0.50	
8.2	Half fair-faced wall with no finishes/pre-finished			0.40	
8.3	Full fair-faced/glass block wall with no finishes/pre-finished			0.30	

WALL SYSTEM		AREA (M ²) (a)	% AREA (b)	LABOUR SAVING INDEX (c)	BUILDABILITY SCORE (b) x (c) x 30
9 OTHER WALL SYSTEMS NOT LISTED IN BDAS					
Total wall area (external wall area and internal wall area)					
Sub-total for wall system (B) (maximum 30 points)					
BUILDABLE FEATURES	MODULE	UNIT OF COVERAGE		VALUE FOR THIS PROJECT IN %	BUILDABILITY SCORE
		≥65%-<80%	≥80%		
1 STANDARDISATION					
1.1	Columns (3 most common sizes) - in nos.	0.5M	N.A.	2.00	
1.2	Beams (3 most common sizes) - in nos.	0.5M	N.A.	2.00	
1.3	(a) Standard door leaf openings (width) (3 most common sizes) (see Table 3A) - in nos.	N.A.	0.50	1.00	
OR					
	(b) Standard door leaf openings (width) and standard structural openings (3 most common sizes) (see Table 3A) - in nos.	N.A.	1.00	2.00	
OR					
	(c) Standard structural openings for doors (3 most common sizes) (for sizes not within the range stipulated in Table 3A) - in nos.	2M or 3M	0.50	1.00	
1.4	Windows (3 most common sizes) - in nos.	1M/1M	0.50	1.00	
2 GRIDS					
2.1	(a) Repetition of horizontal grids (between supports) (3 most common dimensions) - in nos.	1M	1.00	1.50	
OR					
	(b) Repetition of horizontal grids (between supports) (3 most common dimensions) - in nos.	3M	1.50	2.00	
2.2	Repetition of floor-to-floor height - in nos.	0.5M	1.00	2.00	
2.3	Vertical repetition of structural floor layout - in areas	N.A.	1.50	2.00	
3 PREFABRICATED REINFORCEMENT					
3.1	Floor - in areas	N.A.	1.00	1.50	
3.2	Wall - in areas	N.A.	1.00	1.50	
3.3	Beam cage - in nos.	N.A.	1.50	2.00	
3.4	Column cage - in nos.	N.A.	1.50	2.00	

BUILDABLE FEATURES	MODULE	UNIT OF COVERAGE		VALUE FOR THIS PROJECT IN %	BUILDABILITY SCORE
		≥65%-<80%	≥80%		
4 OTHERS					
4.1 (a) Prefabricated bathroom/toilet complete with piping/wiring: prefabricated wall panels and floor tray separately assembled - in nos.	0.5M	1.50	2.00		
OR					
(b) Prefabricated bathroom/toilet complete with piping/wiring: full prefabricated cell completed with finished wall and floor - in nos.	0.5M	2.00	3.00		
4.2 (a) Standard precast staircase (see Table 3B) - in nos.	N.A.	N.A.	2.00		
OR					
(b) Pre-assembled/metal staircase - in nos.	N.A.	N.A.	2.00		
4.3 Prefabricated vertical shafts (e.g. refuse chutes) - in nos.	N.A.	N.A.	1.00		
4.4 Multi-tier precast columns - in nos.	N.A.	N.A.	2.00		
4.5 (a) Precast CD shelters: minimum 2 panels precast - in nos.	0.5M	1.00	1.50		
OR					
(b) Precast CD shelters: full precast cells - in nos.	0.5M	2.00	3.00		
4.6 Non-screed floor - in areas	N.A.	N.A.	1.00		
4.7 Columns sit directly on top of piles - in nos.	N.A.	N.A.	0.50		
4.8 Ground beams on top of pilecaps - in nos.	N.A.	N.A.	0.50		
4.9 Diaphragm wall construction - in areas	N.A.	N.A.	1.50		
5 OTHER BUILDABLE FEATURES NOT LISTED IN BDAS					
Sub-total for other buildable design features (C) (maximum 20 points)					
GRAND TOTAL (A + B + C)					

EXPLANATORY NOTES

Form BPD_BS01

Form BPD_BS01 must be completed and submitted together with the application for approval of building plans for projects subjected to buildability requirement. For projects with multiple blocks, please submit 1 copy of the “Appendix 1” form for every block. In the event when any design is not fully developed, the QP must declare the types of building (structural or architectural) system to be used by stating the percentage of areas (floor or wall) to be constructed with a particular system.

For example, 70% of the floor areas will be using flat plate and the remaining 30% of the floor areas are using beam-slab system. The table should be filled in as follows:

STRUCTURAL SYSTEM	AREA (M ²)	% AREA	LABOUR SAVING INDEX	BUILDABILITY SCORE
Flat plate		70%		
Beam-slab system		30%		

APPLICATION FOR APPROVAL OF STRUCTURAL PLANS
Section 6(1) of the Building Control Act (Cap.29)

Commissioner of Building Control
 Building and Construction Authority
 5 Maxwell Road #02-00
 Tower Block, MND Complex
 Singapore 069110

INSTRUCTIONS
 1 This Form is to be completed for AC and Non-AC Projects.
 2 Tick the appropriate box.
 3 * Delete accordingly.
 4 Please use BLACK INK to complete the form.
 Note - Guidelines for Submission of Structural Plans and Calculations BEV/A1-GUIDELINE are available at BCA Service Counter.

SECTION I (To be completed by Applicant)

1 I hereby apply for approval of the *site formation/piling/structural plans and calculations for:
 Project Reference No.: _____
 Project Title: _____

 *Lot/Plot: _____ *TS/MK: _____
 House No: _____ Road: _____

2	<p><u>Classification of Works</u></p> <input type="checkbox"/> New developments <input type="checkbox"/> A/A works <input type="checkbox"/> Retention works Number of Storeys: _____ Value of Building Works: _____	<p><u>Type of Works</u></p> <input type="checkbox"/> Site formation <input type="checkbox"/> Piling works <input type="checkbox"/> Sub-structural works <input type="checkbox"/> Super-structural works <input type="checkbox"/> Cladding/Curtain Wall <input type="checkbox"/> Retaining wall	<p><u>Usage</u></p> <input type="checkbox"/> Residential (landed) <input type="checkbox"/> Residential (non-landed) <input type="checkbox"/> Commercial <input type="checkbox"/> Institutional <input type="checkbox"/> Bridge/Jetty <input type="checkbox"/> Industrial
---	---	---	---

3 The Plans are

structural plans of project ref. no.: _____

amendment plans to structural plans of project ref. no.: _____ ST _____

the first plans to be submitted under this project and building plan submission will be made subsequently

the first plans to be submitted under this project and building plan submission is inapplicable

4 Before making this application, under the Building Control Act, I had appointed the following:

(a) Qualified Person for structural works
 Name: _____, PE Registration No.: _____

(b) Accredited Checker (AC):

(i) AC in an Accredited Checking Organisation (ACO):
 Name of AC _____, AC Registration No.: _____
 Name of ACO _____, ACO Registration No.: _____

or

(ii) AC acting on his own behalf & not in an ACO:
 Name of AC _____, AC Registration No.: _____

(Note: Fill **either** (b)(i) or (ii) as appropriate and note that for (b)(ii), AC not in an ACO is restricted to undertake work in a project with a value of building works up to \$10 million)

5 I confirm that the works on the proposal

have not commenced

were commenced on _____ *with/without the prior permit of the Commissioner of Building Control

Name & Address of Applicant

Tel No.: _____ Date: _____

Name & Designation of authorised signatory
 (if applicant is a company)

Signature: _____

NRIC No.: _____

**SUBMISSION OF STRUCTURAL BUILDABILITY SCORE CALCULATIONS
Regulation 6 of the Building Control (Buildable Design) Regulations (Cap.29)**

Commissioner of Building Control
Building & Construction Authority
5 Maxwell Road #02-00
Tower Block, MND Complex
Singapore 069110

INSTRUCTIONS

- 1 Please refer to the Explanatory Notes attached before completing these forms.
- 2 Use a separate set of BEV/A1_BS02_Appendix 1 for each block of the building in the project.
- 3 *Delete accordingly.
- 4 Please use BLACK INK to complete the form.
- 5 One copy of this form is to be submitted at the first submission for superstructural works.

SECTION I (To be completed by the Qualified Person for structural works)

I hereby submit the provisional buildability scores of the structural works for the project described herein and BEV/A1_BS02_Appendix 1 is attached.

Project Reference No.: _____

Description of building works: _____

Buildability score of structural works: _____

The overall buildability score for the above project shall be submitted at the application for approval of building plans.

Name & Address of Professional Firm

Name & Signature of Qualified Person for structural works

Date:

Tel No.:

SECTION II (To be completed by the Qualified Person for architectural works)

I have noted the buildability score of the structural works submitted by the Qualified Person for Structural Works.

The overall buildability score for the above project shall be submitted at the application for approval of building plans.

Name & Address of Professional Firm

Name & Signature of Qualified Person for architectural works

Date:

Tel No.:

CALCULATIONS OF STRUCTURAL BUILDABILITY SCORE
Regulation 6 of the Building Control (Buildable Design) Regulations (Cap.29)

PART I : PROJECT DETAILS

Project Reference No.: _____
 Block No./Name: _____ Total no. of blocks: _____
 Please indicate other typical blocks (if any): _____

Category of Building (for mixed development, more than 1 box may be ticked):

Residential (landed) Residential (non-landed) Commercial
 Industrial Institutional & others

For mixed development, please indicate the GFA for each category:

Residential (landed) _____ m²
 Residential (non-landed) _____ m²
 Commercial _____ m²
 Industrial _____ m²
 Institutional & others _____ m²

PART II : COMPUTATION OF BUILDABILITY SCORE

STRUCTURAL SYSTEM	AREA (M ²) (a)	% AREA (b)	LABOUR SAVING INDEX (c)	BUILDABILITY SCORE (b) x (c) x 50
1 STEEL BEAM				
1.1 Steel beam with column in sprayed fire proofed with:				
1.1.1 cast-in-place slab on steel decking			0.95	
1.1.2 precast concrete slab			0.90	
1.2 Steel beam with column encased in concrete with:				
1.2.1 cast-in-place slab on steel decking			0.85	
1.2.2 precast concrete slab			0.80	
2 PRECAST CONCRETE BEAM				
2.1 with precast column/wall with precast concrete slab			1.00	
2.2 with in-situ cast column/wall with precast concrete slab			0.90	
3 NO INTERNAL BEAM				
3.1 with precast column/wall				
3.1.1a with flat plate (post-tensioned/prestressed)			0.95	
3.1.1b with flat plate (without post-tensioned/prestressed)			0.90	
3.2 with cast in-situ column/wall				
3.2.1a with flat plate (post-tensioned/prestressed)			0.90	
3.2.1b with flat plate (without post-tensioned/prestressed)			0.85	
3.2.2a with flat slab (post-tensioned/prestressed)			0.85	
3.2.2b with flat slab (without post-tensioned/prestressed)			0.80	
4 CAST IN-SITU BEAM AND COLUMN/WALL				
4.1 precast concrete slab (without transfer beams) (slab/beam > 10) with:				
4.1.1a cast in-situ beams (post-tensioned/prestressed)			0.75	
4.1.1b cast in-situ beams (without post-tensioned/prestressed)			0.70	

STRUCTURAL SYSTEM		AREA (M ²) (a)	% AREA (b)	LABOUR SAVING INDEX (c)	BUILDABILITY SCORE (b) x (c) x 50
4.2	precast concrete slab (without transfer beams) (slab/beam ≤ 10) with:				
4.2.1a	cast in-situ beams (post-tensioned/prestressed)			0.65	
4.2.1b	cast in-situ beams (without post-tensioned/prestressed)			0.60	
4.3	cast in-situ slab (without transfer beams) (slab/beam > 10) with:				
4.3.1a	1-way banded beam with slabs/beams (post-tensioned/prestressed)			0.75	
4.3.1b	1-way banded beam with slabs/beams (without post-tensioned/prestressed)			0.70	
4.3.2a	2-way beam with slabs/beams (post-tensioned/prestressed)			0.70	
4.3.2b	2-way beam with slabs/beams (without post-tensioned/prestressed)			0.65	
4.4	cast in-situ slab (without transfer beams) (slab/beam ≤ 10) with:				
4.4.1a	slabs/beams (post-tensioned/prestressed)			0.55	
4.4.1b	slabs/beams (without post-tensioned/prestressed)			0.50	
4.5	cast in-situ slabs (with transfer beams) - applicable to projects submitted for planning approval on or after 1 st Aug 2002 only			0.40	
5 ROOF SYSTEM					
5.1	Integrated metal roof on steel truss			0.90	
5.2	Metal roof on steel truss			0.85	
5.3	Tiled roof on steel beam or PC concrete beam or timber beam			0.75	
5.4	Tiled roof with cast in-situ beam			0.55	
5.5	Concrete roof (constructed area shall be included in the slab design above)				
6 OTHER STRUCTURAL SYSTEMS NOT LISTED IN BDAS					
Total floor area including roof area				Sub-total for structural system (A) (maximum 50 points)	
BUILDABLE FEATURES	MODULE	UNIT OF COVERAGE		VALUE FOR THIS PROJECT IN %	BUILDABILITY SCORE
		≥65%-<80%	≥80%		
1 STANDARDISATION					
1.1	Columns (3 most common sizes) - in nos.	0.5M	N.A.	2.00	
1.2	Beams (3 most common sizes) - in nos.	0.5M	N.A.	2.00	
1.3	(a) Standard door leaf openings (width) (3 most common sizes) (see Table 3A) - in nos.	N.A.	0.50	1.00	
OR					
	(b) Standard door leaf openings (width) and standard structural openings (3 most common sizes) (see Table 3A) - in nos.	N.A.	1.00	2.00	
OR					
	(c) Standard structural openings for doors (3 most common sizes) (for sizes not within the range stipulated in Table 3A) - in nos.	2M or 3M	0.50	1.00	

BUILDABLE FEATURES	MODULE	UNIT OF COVERAGE		VALUE FOR THIS PROJECT IN %	BUILDABILITY SCORE
		≥65%<80%	≥80%		
1.4 Windows (3 most common sizes) - in nos.	1M/1M	0.50	1.00		
2 GRIDS					
2.1 (a) Repetition of horizontal grids (between supports) (3 most common dimensions) - in nos.	1M	1.00	1.50		
OR					
(b) Repetition of horizontal grids (between supports) (3 most common dimensions) - in nos.	3M	1.50	2.00		
2.2 Repetition of floor-to-floor height - in nos.	0.5M	1.00	2.00		
2.3 Vertical repetition of structural floor layout - in areas	N.A.	1.50	2.00		
3 PREFABRICATED REINFORCEMENT					
3.1 Floor - in areas	N.A.	1.00	1.50		
3.2 Wall - in areas	N.A.	1.00	1.50		
3.3 Beam cage - in nos.	N.A.	1.50	2.00		
3.4 Column cage - in nos.	N.A.	1.50	2.00		
4 OTHERS					
4.1 (a) Prefabricated bathroom/toilet complete with piping/wiring; prefabricated wall panels and floor tray separately assembled - in nos.	0.5M	1.50	2.00		
OR					
(b) Prefabricated bathroom/toilet complete with piping/wiring; full prefabricated cell completed with finished wall and floor - in nos.	0.5M	2.00	3.00		
4.2 (a) Standard precast staircase (see Table 3B) - in nos.	N.A.	N.A.	2.00		
OR					
(b) Pre-assembled/metal staircase - in nos.	N.A.	N.A.	2.00		
4.3 Prefabricated vertical shafts (eg. refuse chutes) - in nos.	N.A.	N.A.	1.00		
4.4 Multi-tier precast columns - in nos.	N.A.	N.A.	2.00		
4.5 (a) Precast CD shelters: minimum 2 panels precast - in nos.	0.5M	1.00	1.50		
OR					
(b) Precast CD shelters: full precast cells - in nos.	0.5M	2.00	3.00		
4.6 Non-screed floor - in areas	N.A.	N.A.	1.00		
4.7 Columns sit directly on top of piles - in nos.	N.A.	N.A.	0.50		
4.8 Ground beams on top of pilecaps - in nos.	N.A.	N.A.	0.50		
4.9 Diaphragm wall construction - in areas	N.A.	N.A.	1.50		

BUILDABLE FEATURES	MODULE	UNIT OF COVERAGE		VALUE FOR THIS PROJECT IN %	BUILDABILITY SCORE
		≥65%-<80%	≥80%		
5 OTHER BUILDABLE FEATURES NOT LISTED IN BDAS					
Sub-total for buildable design features(C) (maximum 20 points)					
GRAND TOTAL(A + B + C)					

EXPLANATORY NOTES

Form BEV/A1_BS02

Form BEV/A1_BS02 must be completed and submitted together with the 1st submission for approval of plans for superstructural works. Please submit 1 copy of “Appendix 1” form for every block. The structural buildability score submitted is to be for the whole development. In the event that the structural designs are not fully developed, the QP for structural works can state the percentage of floors areas to constructed using a particular structural system.

For example, 70% of the floor areas will be using flat plate and the remaining 30% of the floor areas are using beam-slab system. Appendix 1 should be filled in as follows:

STRUCTURAL SYSTEM	AREA (M ²)	% AREA	LABOUR SAVING INDEX	BUILDABILITY SCORE
Flat plate		70%		
Beam-slab system		30%		

**SUBMISSION OF AS-BUILT BUILDABILITY SCORE CALCULATIONS
Regulation 7 of the Building Control (Buildable Design) Regulations (Cap.29)**

Commissioner of Building Control
Building & Construction Authority
5 Maxwell Road #02-00
Tower Block, MND Complex
Singapore 069110

INSTRUCTIONS

- 1 Please refer to the Explanatory Notes attached before completing these forms.
- 2 Use a separate set of forms BPD_BS03_Appendix 1 for each block of the building in the project.
- 3 * Delete accordingly.
- 4 Please use **BLACK INK** to complete the form.
- 5 Please tick (✓) the appropriate boxes.

SECTION I (To be completed by Qualified Persons)

1 Project Reference No.: _____
Description of building works: _____

2 We, the Qualified Persons for the abovementioned project, hereby jointly declare that the as-built buildability score is _____. We further declare that:

- The as-built buildability score is the same as the buildability score submitted at the application of building plan approval and this score exceeds the minimum score stipulated in the Building Control (Buildable Design) Regulations.
- The as-built buildability score is different from the buildability score submitted at the application of building plan approval and this score exceeds the minimum score stipulated in the Building Control (Buildable Design) Regulations. BPD_BS03_Appendix 1 is attached.

Name & Address of Professional Firm

Name & Signature of Qualified Person for architectural works

Date:

Tel No.:

Name & Address of Professional Firm

Name & Signature of Qualified Person for structural works

Date:

Tel No.:

CALCULATIONS OF AS-BUILT BUILDABILITY SCORE
Regulation 7 of the Building Control (Buildable Design) Regulations (Cap.29)

PART I : PROJECT DETAILS

Project Reference No.: _____
 Block No./Name: _____ Total no. of blocks: _____
 Project indicate other typical blocks (if any): _____

Category of Building (for mixed development, more than 1 box may be ticked):

Residential (landed) Residential (non-landed) Commercial
 Industrial Institutional & others

Gross Floor Areas of building works:

$\geq 5000 \text{ m}^2$ but less than 25000 m^2 $\geq 25000 \text{ m}^2$

For mixed development, please indicate the GFA for each category:

Residential (landed) _____ m^2
 Residential (non-landed) _____ m^2
 Commercial _____ m^2
 Industrial _____ m^2
 Institutional & others _____ m^2

PART II : COMPUTATION OF BUILDABILITY SCORE

STRUCTURAL SYSTEM	AREA (M ²) (a)	% AREA (b)	LABOUR SAVING INDEX (c)	BUILDABILITY SCORE (b) x (c) x 50
1 STEEL BEAM				
1.1 Steel beam with column in sprayed fire proofed with:				
1.1.1 cast-in-place slab on steel decking			0.95	
1.1.2 precast concrete slab			0.90	
1.2 Steel beam with column encased in concrete with:				
1.2.1 cast-in-place slab on steel decking			0.85	
1.2.2 precast concrete slab			0.80	
2 PRECAST CONCRETE BEAM				
2.1 with precast column/wall with precast concrete slab			1.00	
2.2 with cast in-situ column/wall with precast concrete slab			0.90	
3 NO INTERNAL BEAM				
3.1 with precast column/wall				
3.1.1a with flat plate (post-tensioned/prestressed)			0.95	
3.1.1b with flat plate (without post-tensioned/prestressed)			0.90	
3.2 with cast in-situ column/wall				
3.2.1a with flat plate (post-tensioned/prestressed)			0.90	
3.2.1b with flat plate (without post-tensioned/prestressed)			0.85	
3.2.2a with flat slab (post-tensioned/prestressed)			0.85	
3.2.2b with flat slab (without post-tensioned/prestressed)			0.80	

STRUCTURAL SYSTEM		AREA (M ²) (a)	% AREA (b)	LABOUR SAVING INDEX (c)	BUILDABILITY SCORE (b) x (c) x 50
4 CAST IN-SITU BEAM AND COLUMN/ WALL					
4.1	precast concrete slab (without transfer beams) (slab/beam > 10) with:				
4.1.1a	cast in-situ beams (post-tensioned/prestressed)			0.75	
4.1.1b	cast in-situ beams (without post-tensioned/prestressed)			0.70	
4.2	precast concrete slab (without transfer beams) (slab/beam ≤ 10) with:				
4.2.1a	cast in-situ beams (post-tensioned/prestressed)			0.65	
4.2.1b	cast in-situ beams (without post-tensioned/prestressed)			0.60	
4.3	cast in-situ slab (without transfer beams) (slab/beam >10) with:				
4.3.1a	1-way banded beam with slabs/beams (post-tensioned/prestressed)			0.75	
4.3.1b	1-way banded beam with slabs/beams (without post-tensioned/prestressed)			0.70	
4.3.2a	2-way beam with slabs/beams (post-tensioned/prestressed)			0.70	
4.3.2b	2-way beam with slabs/beams (without post-tensioned/prestressed)			0.65	
4.4	cast in-situ slab (without transfer beams) (slab/beam ≤ 10) with:				
4.4.1a	slabs/beams (post-tensioned/prestressed)			0.55	
4.4.1b	slabs/beams (without post-tensioned/prestressed)			0.50	
4.5	cast in-situ slabs (with transfer beams) - applicable to projects submitted for planning approval on or after 1 st Aug 2002 only			0.40	
5 ROOF SYSTEM					
5.1	Integrated metal roof on steel truss			0.90	
5.2	Metal roof on steel truss			0.85	
5.3	Tiled roof on steel beam or PC concrete beam or timber beam			0.75	
5.4	Tiled roof with cast in-situ beam			0.55	
5.5	Concrete roof (constructed area shall be included in the slab design above)				
6 OTHER STRUCTURAL SYSTEMS NOT LISTED IN BDAS					
Total floor area including roof area					
Sub-total for structural system (A) (maximum 50 points)					

BUILDABLE FEATURES	MODULE	UNIT OF COVERAGE		VALUE FOR THIS PROJECT IN %	BUILDABILITY SCORE
		≥65%<80%	≥80%		
1 STANDARDISATION					
1.1 Columns (3 most common sizes) - in nos.	0.5M	N.A.	2.00		
1.2 Beams (3 most common sizes) - in nos.	0.5M	N.A.	2.00		
1.3 (a) Standard door leaf openings (width) (3 most common sizes) (see Table 3A) - in nos.	N.A.	0.50	1.00		
OR					
(b) Standard door leaf openings (width) and standard structural openings (3 most common sizes) (see Table 3A) - in nos.	N.A.	1.00	2.00		
OR					
(c) Standard structural openings for doors (3 most common sizes) (for sizes not within the range stipulated in Table 3A) - in nos.	2M or 3M	0.50	1.00		
1.4 Windows (3 most common sizes) - in nos.	1M/1M	0.50	1.00		
2 GRIDS					
2.1 (a) Repetition of horizontal grids (between supports) (3 most common dimensions) - in nos.	1M	1.00	1.50		
OR					
(b) Repetition of horizontal grids (between supports) (3 most common dimensions) - in nos.	3M	1.50	2.00		
2.2 Repetition of floor-to-floor height - in nos.	0.5M	1.00	2.00		
2.3 Vertical repetition of structural floor layout - in areas	N.A.	1.50	2.00		
3 PREFABRICATED REINFORCEMENT					
3.1 Floor - in areas	N.A.	1.00	1.50		
3.2 Wall - in areas	N.A.	1.00	1.50		
3.3 Beam cage - in nos.	N.A.	1.50	2.00		
3.4 Column cage - in nos.	N.A.	1.50	2.00		
4 OTHERS					
4.1 (a) Prefabricated bathroom/toilet complete with piping/wiring: prefabricated wall panels and floor tray separately assembled - in nos.	0.5M	1.50	2.00		
OR					
(b) Prefabricated bathroom/toilet complete with piping/wiring: full prefabricated cell completed with finished wall and floor - in nos.	0.5M	2.00	3.00		
4.2 (a) Standard precast staircase (see Table 3B) - in nos.	N.A.	N.A.	2.00		
OR					
(b) Pre-assembled/metal staircase - in nos.	N.A.	N.A.	2.00		
4.3 Prefabricated vertical shafts (e.g. refuse chutes) - in nos.	N.A.	N.A.	1.00		
4.4 Multi-tier precast columns - in nos.	N.A.	N.A.	2.00		
4.5 (a) Precast CD shelters: minimum 2 panels precast - in nos.	0.5M	1.00	1.50		
OR					
(b) Precast CD shelters: full precast cells - in nos.	0.5M	2.00	3.00		

BUILDABLE FEATURES	MODULE	UNIT OF COVERAGE		VALUE FOR THIS PROJECT IN %	BUILDABILITY SCORE
		≥65%-<80%	≥80%		
4.6 Non-screed floor - in areas	N.A.	N.A.	1.00		
4.7 Columns sit directly on top of piles - in nos.	N.A.	N.A.	0.50		
4.8 Ground beams on top of pilecaps - in nos.	N.A.	N.A.	0.50		
4.9 Diaphragm wall construction - in areas	N.A.	N.A.	1.50		
5 OTHER BUILDABLE FEATURES NOT LISTED IN BDAS					
Sub-total for other buildable design features (C)					
(maximum 20 points)					
GRAND TOTAL (A + B + C)					

EXPLANATORY NOTES

Form BPD_BS03

- (1) Only one copy of this Form need to be submitted. This form is to be submitted within one month of obtaining TOP, or before CSC, whichever is earlier. All items/blanks must be completed. If an item is not applicable, it should be indicated as "N.A."
- (2) For projects with multiple blocks, please submit 1 copy of the BPD_BS03_Appendix 1 for every block.

